

# BNO085/BNO086

## 9-AXIS SYSTEM IN PACKAGE (SIP) IMU

Consisting of the BNO085 and BNO086, our BNO08X family of SiPs (System-in-Package) is perfect for robotics, AR/VR, HIDs (Human Interface Devices, such as remote controls) and other motion-sensing applications. Leveraging our advanced sensor fusion software and a Bosch Sensortec sensor, this powerful platform is highly flexible, and we'll work with your technology teams so you can easily configure it to bring out the best in your product.





The BNO086 delivers high performance, shortens development times and simplifies BOMs by combining a 9-axis sensor (AGM) with sensor fusion capabilities in a single package. By addressing popular sensor anomalies with proprietary algorithms that are continually perfected through rigorous testing, our motion sensors deliver more accurate dynamic heading than the competition. We've built a deep and flexible sensor platform so you can pick what works best for you – stay focused on innovating in other product areas while speeding time to market. Leave the sensor fusion to the experts.



### FEATURE HIGHLIGHTS

- ✓ MotionEngine™ 9-Axis and 6-Axis Sensor Fusion – Provides raw, calibrated sensor orientation data for more accurate heading and orientation
- ✓ Intelligent Power Management – Manages sensor states to conserve power without sacrificing quality of motion data
- ✓ Calibration – Supports both dynamic and factory-based calibration to deliver the highest performance. The BNO086 includes CEVA's Interactive Calibration, bringing even greater accuracy to robotics applications
- ✓ Compatibility – BNO086 is backwards compatible with BNO085 and both are pin-for-pin replacements for Bosch Sensortec's BNO055 and BMF055
- ✓ Always-on Capabilities – Includes software to enable low power, step counter and gesture recognition
- ✓ Control via I2C, SPI or UART Interfaces – Freedom to optimize overall circuit design requirements
- ✓ Secondary I2C interface – Allows attachment of additional environmental sensors
- ✓ OS Independent – Driver example code available for ease of integration
- ✓ Software Library Support – Includes support for external MotionElements software libraries for advanced applications such as 6DOF VR controllers and attitude monitoring (e.g., antennas)

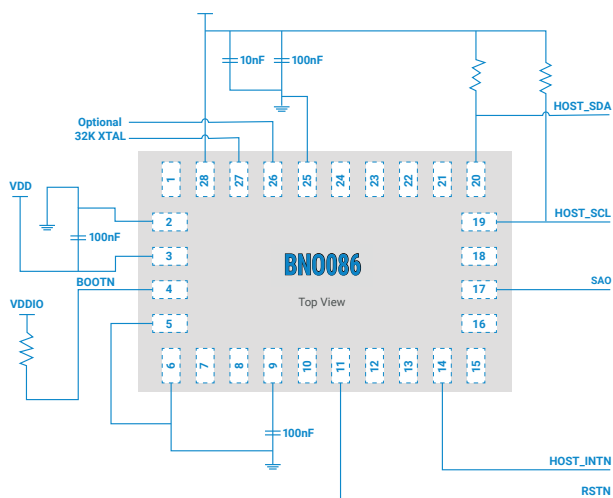

### PHYSICAL ATTRIBUTES

<b>SOFTWARE</b>	 Hillcrest Lab's advanced sensor fusion software
<b>SENSORS</b>	 accel  gyro  mag
<b>PROCESSOR</b>	 ARM Cortex-M0+
<b>INTERFACES</b>	I2C ..... SPI ..... UART



# BNO085/BNO086

## 9-AXIS SYSTEM IN PACKAGE (SiP) IMU

 <b>AR/VR</b>	<b>ROBOTICS</b> 
<p>The BNO08X line delivers more accurate orientation information with low latency – even during rapid motion – eliminating motion sickness and other negative user experiences. Low power consumption, predictive motion, high output rate (1kHz), and compact size (5.2 x 3.8 x 1.1 mm<sup>3</sup>) all make the BNO08X line ideal for VR/AR devices such as HMD (head mounted displays), glasses and controllers, where both power and space are at a premium.</p> <p>Our MotionElements software combines camera data with the sensor data from the BNO085 or BNO086 to deliver a more cost-effective 6DOF controller experience.</p>	<p>The BNO08X family is optimized for service robots that employ Simultaneous Localization and Mapping (SLAM) or other “intelligent” navigation solutions, such as robotic vacuum cleaners.</p> <p>Our combination of proprietary sensor fusion software and multi-axis sensors delivers superior heading performance, even when the robot runs over uneven surfaces, such as a floor transition from one material to another. Interactive Calibration (BNO086 only) uses the robot’s knowledge of its own motion state to provide even greater levels of performance right out of the box. Whether your robot cleaner relies mainly on an IMU for navigation or leverages an IMU to complement a LiDAR, VSLAM system or optical sensor (optical flow), our products will help you meet your requirements.</p>
Features & Benefits	Features & Benefits
<ul style="list-style-type: none"> <li>✓ 1KHz Sample Rate – Enables flawless, smooth head-tracking with low latency and support for time-warping for immersive experiences</li> <li>✓ Predictive Head Tracking and AR/VR Stabilization – Adjusts angular position gradually over time to avoid “jumps” and compensate for system latency</li> <li>✓ Enhanced Controller Tracking - Utilizes camera data to significantly improve VR controller performance</li> <li>✓ Tare – Allows for arbitrary mounting of any BNO08X SiP in the end product</li> <li>✓ Context and Activity Tracking – Step-based activity features for head-mounted devices, including stationary, running, walking and step count</li> </ul>	<ul style="list-style-type: none"> <li>✓ Accurate Heading Angle – Less than 0.16°/min (10°/hr) typical error rate when using Interactive Calibration</li> <li>✓ Tilt Independent Heading – Allows for proper heading output when surface is uneven</li> <li>✓ Bump Detection – Calibrated accelerometer output provides data to support a bump detection algorithm without having to use a separate sensor</li> <li>✓ Inclination Detection – Provides full 3DOF robot orientation, allowing detection of surface and device issues</li> </ul>

### ABOUT CEVA

CEVA is the leading licensor of wireless connectivity and smart sensing technologies. We offer Digital Signal Processors, AI processors, wireless platforms and complementary software for sensor fusion, image enhancement, computer vision, voice input and artificial intelligence, all of which are key enabling technologies for a smarter, more connected world. We partner with semiconductor companies and OEMs worldwide to create power-efficient, intelligent and connected devices for a range of end markets, including mobile, consumer, automotive, robotics, industrial and IoT. Our ultra-low-power IPs include comprehensive platforms comprised of specialized DSPs coupled with an AI and other types of accelerators targeted for low power workloads, including 5G baseband processing, intelligent vision, voice recognition, physical layer processing and sensor fusion. We also offer high performance DSPs targeted for 5G RAN and Open RAN, Wi-Fi enterprise and residential access points, satellite communication and other multi-gigabit communications. Our portfolio also includes a wide range of application software optimized for our processors, including voice front-end processing and speech recognition, imaging and computer vision and sensor fusion. For sensor fusion, our Hillcrest Labs sensor processing technologies provide a broad range of sensor fusion software and inertial measurement unit (“IMU”) solutions for AR/VR, robotics, remote controls and IoT. For wireless IoT, we offer the industry’s most widely adopted IPs for Bluetooth (low energy and dual mode), Wi-Fi 4/5/6 (802.11n/ac/ax) and NB-IoT.

© Copyright 05/2023 CEVA, Inc. and/or its subsidiaries. All rights reserved. All specifications are subject to change without notice.

1000-3962 v3.1

